

Sculptural Interpretation of a Mathematical Form

Robert J. Krawczyk
College of Architecture
Illinois Institute of Technology
3360 South State St., Chicago, IL 60616 USA
krawczyk@iit.edu

Abstract

A number of sculptures have been created based on three-dimensional mathematical forms and surfaces. In most cases, the sculpture is an exact copy of the mathematics that it is based on. This paper explores another method to mathematically create sculptural forms by starting with a two-dimensional figure. The goal is to develop methods and insights on which elements in the original figure can be expressed in three-dimensions and still keep some of the mathematical properties found in the original figure. The creation of each sculptural variation is completed in custom software. The software becomes the modeling material and the sculpting tools.

1. Introduction

There already exists a rich history of using three-dimensional mathematically based forms to create sculpture, both in methods to develop them and actual works of art. Carlo Séquin [1,2] discusses a series of computer based approaches to develop three-dimensional forms that include modeling and procedural generation. Séquin also covers a series of computer assisted methods to actually construct such sculpture and to visualize it. As for actual sculpture, for example, the works of Helaman Ferguson, Charles O. Perry, Robert Longhurst, Brent Collins, Robert Rathburn, and John Robinson; are all described in detail by Ivars Peterson [3]. Most of these works are the result of advanced computer software tools and some by related automated manufacturing techniques. Most use a mathematical basis for generating the form in total, or at least some portion of it. In all cases some related three-dimensional mathematical form is used. In this exploration, a two-dimensional figure is the starting point for interpretation into three-dimensions. The overall concept is to investigate how a basic mathematical form can be expressed in a three-dimensional fashion still keeping many of its original mathematical properties. The two-dimensional figure used here will be a spirolateral.

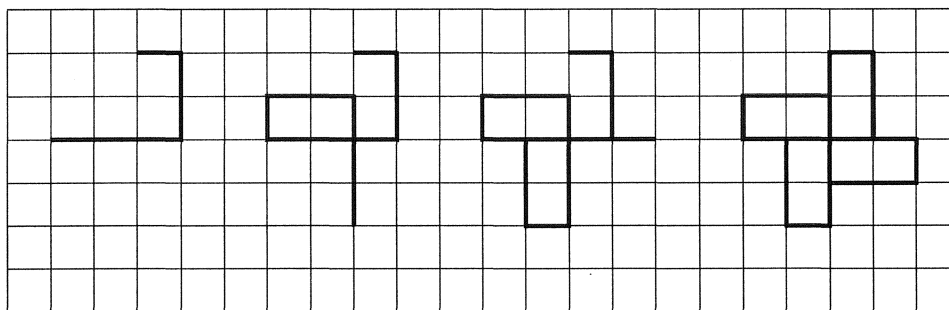

Figure 1: Generation of a 3_{90} spirolateral

A spiroilateral is created by drawing a set of lines; the first at a unit length, then each additional line is increased by one unit length while turning a constant direction. To complete a closed spiroilateral, it is necessary to only repeat this procedure until the starting point is reached. The first apparent reference to this geometric figure was by Odds [4]. Further information was found at Abelson [5] and Gardner [6]. In addition to the property of closure, spirolaterals need not always turn the same direction. The direction can be reversed at any turn, which makes the total number of possible spiroilateral unknown. Figure 1 displays the systematic generation of an order 3 spiroilateral; one that consists of 3 segments at turns of 90 degrees.

Previous research and development by Krawczyk [7,8,9] included identifying a large number of closed spirolaterals using a variety of turning angles, turns, and repeats, including turn reversal. The first set of these were represented by a simple line drawing. To further develop these mathematical figures in an artistic fashion, a line thickness was added and an optional overlay of center and edge lines. This representation was used to create over 300 spirolaterals in galleries found at www.netcom.com/~bitart. Figure 2 displays a few of these, including some with turn reversals. The line thickness gave each spiroilateral an additional variety that did not appear in the simple line version. When the overlapping center and edge lines are included, in addition to segmenting the thick lines visually, they also develop their own unique pattern over the underlying image.

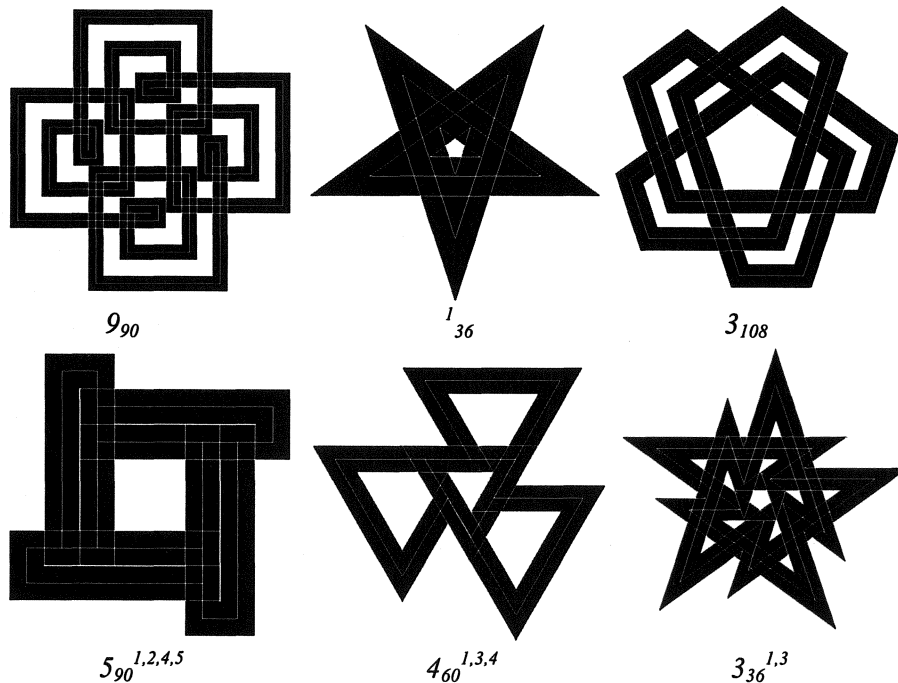

Figure 2: Closed spirolaterals including reversals

All the previous investigations have created spirolaterals in two-dimensions. For this particular series, three-dimensional constructions were investigated. Figure 3 displays the spiroilateral that was selected for this series. Figure 3a. and 3b. are the original spiroilateral, and 3c. is the variation selected. In this version the line thickness is decreased so to better articulate the turns as separate sculptural elements.

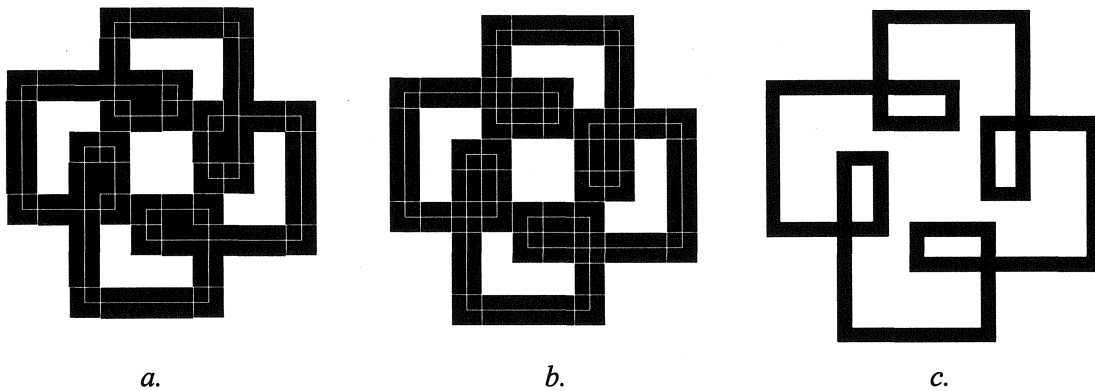

Figure 3: 4_{90} spiroilateral

In moving these figures into the third dimension, an interpretive approach was examined. This approach attempts to use every possible property of the spiroilateral and its potential to define the third dimension. The overall concept was to follow the given geometry, retain the step and turn properties of the original spiroilateral, and retain the entire form. Three basic approaches were explored; as a relief, as an assembly, and as a construction. These were selected to investigate a variety of orientations and develop an interpretation that considers the spiroilateral in its entirety and at by each individual part.

The codes found in the figures are an internal numbering system that have no specific meaning.

2. As a relief

The first interpretation was as a relief, a simple three-dimensional extrusion of the two-dimensional figure. The relief concept continues the line quality of the original spirolaterals in three dimensions. C01 in Figure 4 displays the simplest extrusion that is possible. All of the parts of the spiroilateral have the same dimension and the same height. The extrusion can also be viewed in a positive and negative fashion, C01I in Figure 4 displays the negative and C01J in Figure 4 displays a combination of the positive and negative.

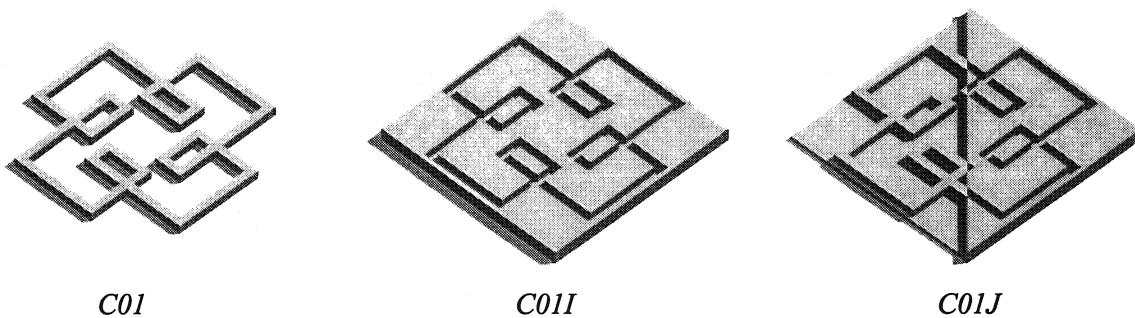
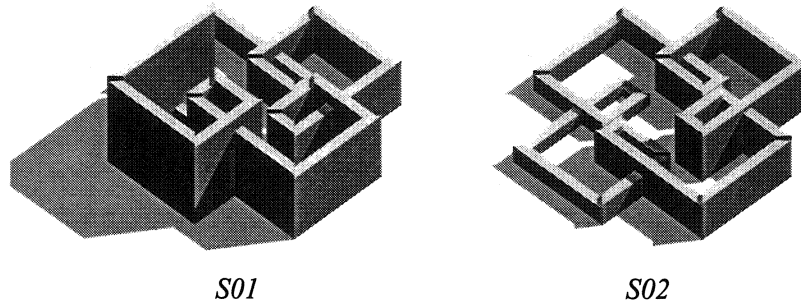

Figure 4: Simple relief, positive and negative

Continuing with the relief concept, the next set of pieces consider the spiroilateral property of turn size and its change in length. First considered is each turn individually, S01 in Figure 5, increases the height of each individual turn from its starting turn to the ending turn, a total of 20 turns. The height parallels the change in turn length. A simple variation of S01 would be to reverse the turn size from increasing to decreasing from the starting turn. Another interpretation of the increasing turn size is to combine the increasing and decreasing turn height. S02 in Figure 5 increases each turn height until the midpoint is reached, then the turn height is decreased.



S01 *S02*
Figure 5: Increasing/decreasing turn height

The next consideration was treating each set of turns as a unit, not as individual turns. S03 in Figure 6 increasing the height of each set of turns, in this case, there are four set of turns. A simple variation of S03 would be to reverse the pattern of height from increasing to decreasing. Another variation is to incorporate both increasing and decreasing. S04 in Figure 6 alternates the height of each set of turns.

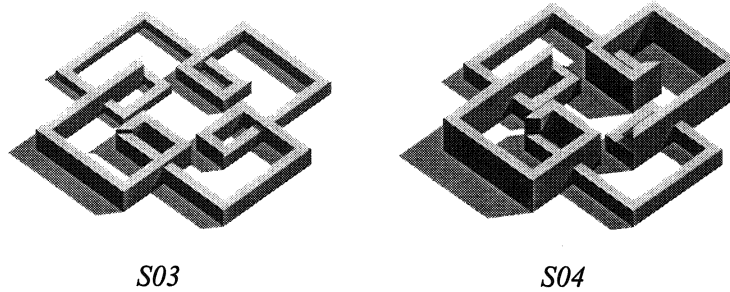

S03 *S04*
Figure 6: Increasing/decreasing set of turn height

Using the same type of variations as in the previous pieces, stepping the turns, a series of variations was considered that ramped the turns. R01 in Figure 7 simply ramps the turn height from the starting turn to the ending. A variation would be to reverse the increasing ramp to decreasing. R03 in Figure 7 increases the ramp from the starting turn to the midpoint and then decreases it to the final turn. R03 can also be varied by revering the increase and decrease direction.

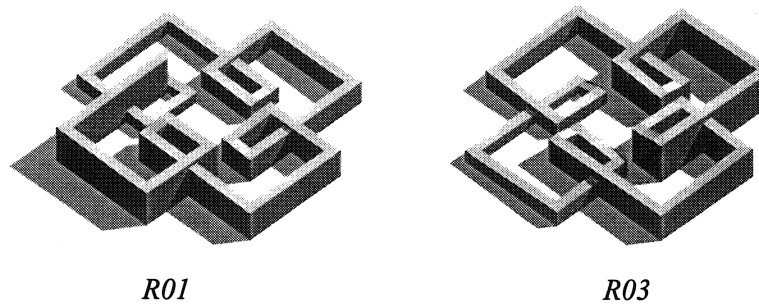

R01 *R03*
Figure 7: Increasing/decreasing turn height as ramps

As with the stepped variations, the ramping can also consider an entire set of turns not just each individual one. R07 in Figure 8 increases the ramp for each set of turns and then resets the ramping to start it over again. R05 in Figure 8 alternates the increasing and decreasing of the ramp for each set of steps. As before a reverse variation is also possible for both R07 and R05.

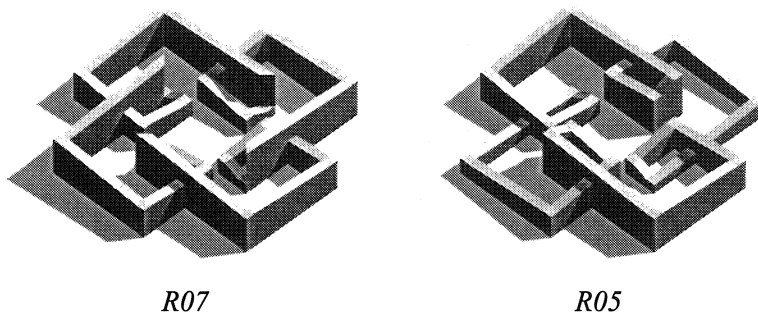

R07 *R05*
Figure 8: *Increasing/decreasing set of turns height as a ramp*

3. As an assembly

A simple assembly can also be created by taking the entire spiroilateral as in the C01 form and combining it with itself. C21 in Figure 9 displays one variation where three C01 forms are combined at the dimensional center of the spiroilateral. One is positioned horizontally and the other two are placed vertically. C22 also combines three C01 forms in the same manner, but at the beginning of the first turn of the spirolaterals. Another variation is to construct a volumetric interpretation, by combining six copies of C01, each copy forms one side of the volume. In this piece, C23 in Figure 10, all the spirolaterals have the same orientation; an additional variation C24 in Figure 10, mirrored opposite sides, so that the spiroilateral meets with common turns at the corners. This simple assembly concept attempted to investigate on how to translate the spiroilateral flatness to a volumetric form.

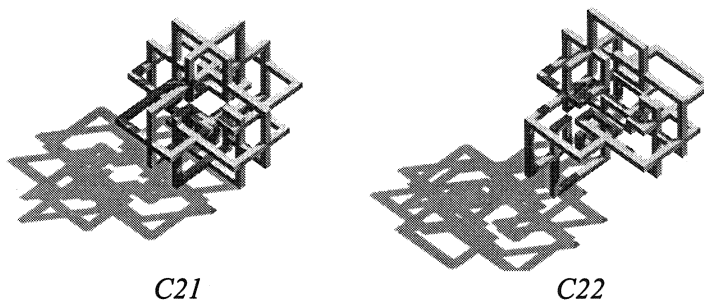

C21 *C22*
Figure 9: *Simple assembly using three copies*

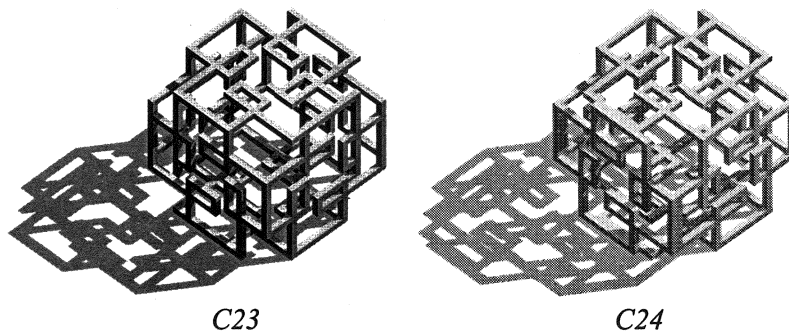

C23 *C24*
Figure 10: *Simple assembly using six copies*

4. As a construction

A set of construction can be created by introducing vertical supports under the entire spiro-lateral, sets of turns, or each individual turn. These supports can have a height based on the turns or sets of turns. The first in the series considers the entire spiro-lateral. L06A in Figure 11 includes the spiro-lateral with supports at each end of each turn with an additional copy of it as a base support. L06B in Figure 11 follows the same concept except the supports are only at the beginning of each set of turns. A simpler variation would exclude the extra copy of the C01 that has been used as additional support.

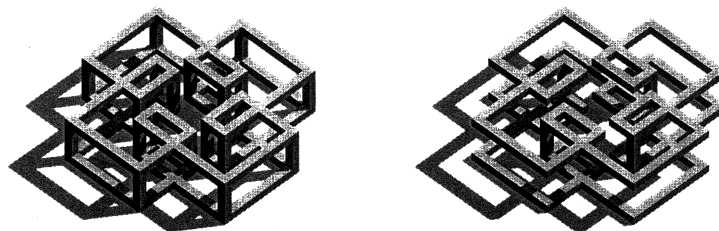

L06A

L06B

Figure 11: Simple construction using the entire spiro-lateral

Following the concepts developed in the step and ramp forms, individual turns or a set of turns, the height of each turn is considered. The first of these was individual turns, L07A in Figure 12 increases the height of each turn, segment by segment throughout the spiro-lateral. Supports are included at each start of each turn. L08A is based on the same concept except that the height is decreased at the midpoint. L05A also exhibits increasing and decreasing but the direction is changed at every set of turns. A copy C01 is placed at the base of each of these for additional support.

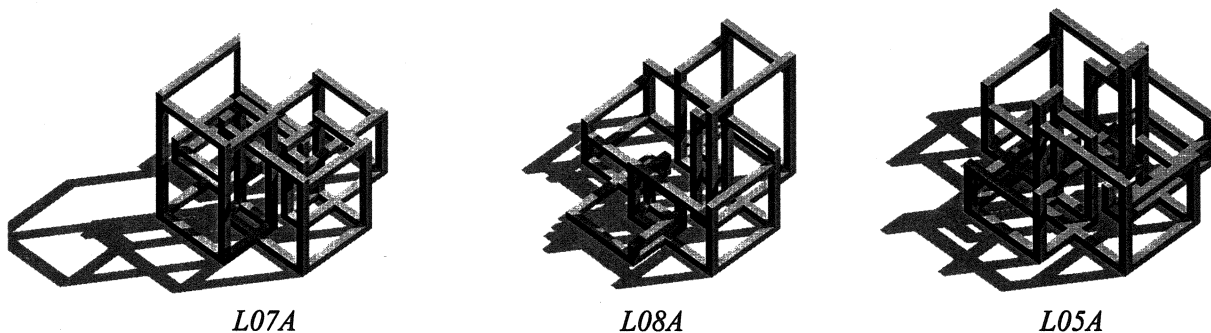

L07A

L08A

L05A

Figure 12: Increasing/decreasing turn height

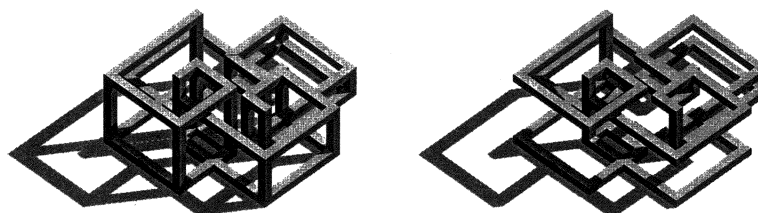

L01A

L01B

Figure 13: Increasing set of turns height

The next set of variations consider a set of turns as a single unit to vary height. L01A in Figure 13 increases each set of turns from the first set to the last. Supports are included at each turn and a base is included for additional support. L01B in Figure 13 is similar to L01A except supports are only placed at the start of each set of turns. A variation to both of these would be to reverse the direction of the height from low-to-high to high-to-low.

An additional variation of these two is to start the first set of turns above the base. L02B and L03B in Figure 14 display two such variations by increasing the initial position of the first set of turns. These also have the additional variation of locating supports at each turn rather than one for each set of turns.

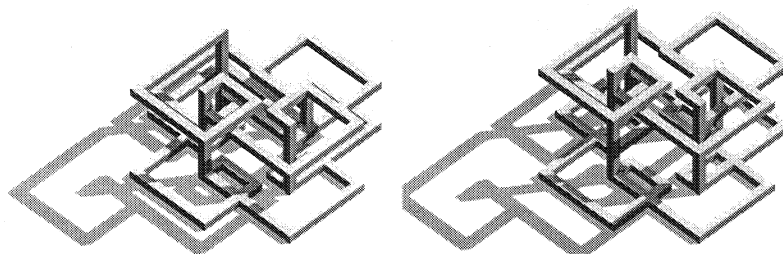

L02B

L03B

Figure 14: *Increasing set of turns height variation*

The final variation in this series, repeats a variation developed as steps. L04A in Figure 15 alternates the height of each set of turns with supports at each turn and L04B which includes supports only at each set of turns. In this case, C01 as an additional support was not added, so that the spiro-lateral figure remained clearly visible.

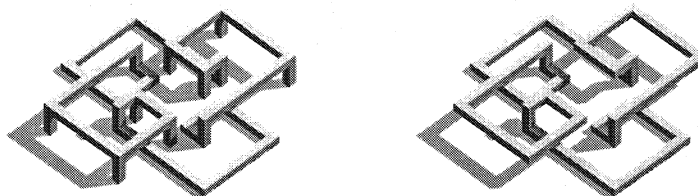

L04A

L04B

Figure 15: *Alternating the set of turns height*

5. Observations

A large number of variations to the sculptural interpretation of the spiro-lateral was able to be developed. Three approaches investigated were; as a relief, as an assembly, and as a construction. The incremental increase in the spiro-lateral mathematical form appeared to be translatable into three-dimensions as steps, as a ramp, and also as step turns. The individual turns of the spiro-lateral were also easily modeled, as well as, each series of individual turns as single units. The spiro-lateral was also able to be interpreted by using its entirety, a set of turns, or the individual turns themselves as organizing elements. In all cases, the overall spiro-lateral figure was still visible. Each method investigated a variety of ways of interpreting a flat figure into three dimensions.

As the variations were being developed, it became easier to write the corresponding software and also envision other possible alternatives. One variation that was not presented here is the transforming the spiroilateral by mapping it onto a cylinder and a sphere. In that case, basic three-dimensional forms are used as a supporting framework for the spiroilateral. Other such mappings could also be investigated.

In exploring all of these, the orientation and final scale of the sculpture was also considered. The reliefs could be small in scale, desktop size, or wall hung. Enlarging the scale, they could also be used for outdoor seating. Many of the reliefs could be combined, created back-to-back, even with opposite types, and hung as mobiles. The assemblies could be scaled for a desktop or larger, large enough for the person to walk into. These could also be created into mobiles. The constructions could also be a variety of scales, but they seem to lend themselves to the scale of furniture, small tables in particular. These also could be used outdoors for sitting and climbing areas. At a smaller scale, some could be created as jewelry.

As variations appeared and were developed, interest became more focused on the continuing interpretation potential, than any one single sculptural form. What further challenges this type of approach is that there are over 300 other spirolaterals that could be interpreted in a similar manner. A discussion could be started on what is more important, any individual result or the development of a concept and an approach?

References

- [1] Séquin, Carlo, 1998, "Art, Math, and Computers: New Ways of Creating Pleasing Shapes", in *Bridges: Mathematical Connection in Art, Music, and Science 1998*, edited by Reza Sarhangi, Southwestern College
- [2] Séquin, Carlo, 2000, "Turning Mathematical Model into Sculptures", in *The Millennial Open Symposium on the Arts and Interdisciplinary Computing*, edited by D. Salesin and C. Sequin, University of Washington
- [3] Peterson, Ivars, 2001, *Fragments of Infinity, A Kaleidoscope of Math and Art*, John Wiley & Sons
- [4] Odds, Frank, "Spirolaterals", *Mathematics Teacher*, February 1973, pp.121-124
- [5] Abelson, Harold, diSessa, Andera, 1968, *Turtle Geometry*, MIT Press, pp.37-39, 120-122
- [6] Gardner, Martin, 1986, *Knotted Doughnuts and Other Mathematical Entertainments*, W. H. Freeman and Company, pp. 205-208
- [7] Krawczyk, Robert, 1999, "Spirolaterals, Complexity from Simplicity", in *International Society of Arts, Mathematics and Architecture 1999*, edited by N. Friedman and J. Barrallo, The University of the Basque Country, pp. 293-299
- [8] Krawczyk, Robert, 2000, "The Art of Spirolaterals", in *The Millennial Open Symposium on the Arts and Interdisciplinary Computing*, edited by D. Salesin and C. Sequin, University of Washington, pp. 127-136
- [9] Krawczyk, Robert, 2000, "The Art of Spirolateral Reversal", in *International Society of Arts, Mathematics and Architecture 2000*, edited by N. Friedman, University of Albany-SUNY